

Connecting diagram

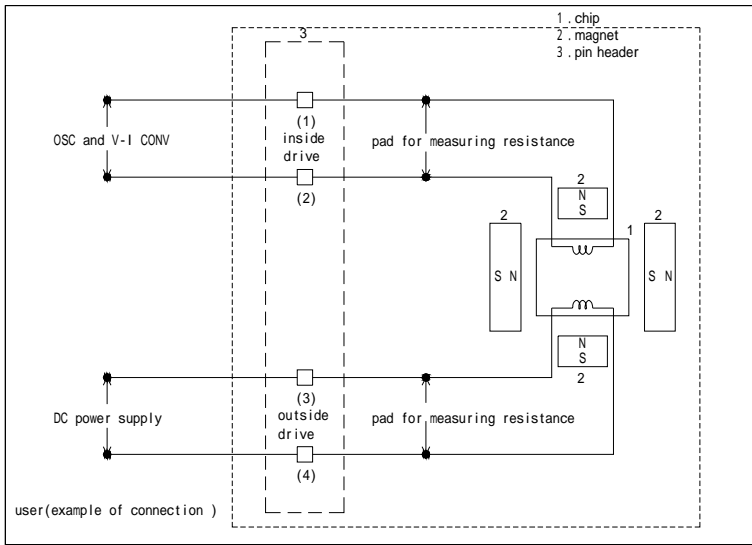

Characteristic data(Reference characteristics)

Characteristics of frequency-amplitude
(Inside / Sine wave driving)

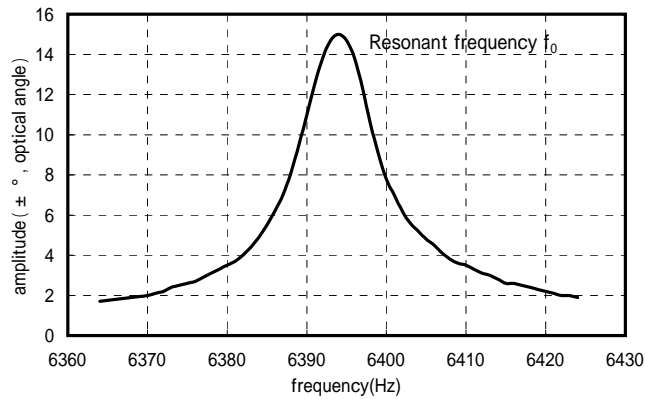

Characteristics of Current-amplitude
(Inside / Sine wave driving)

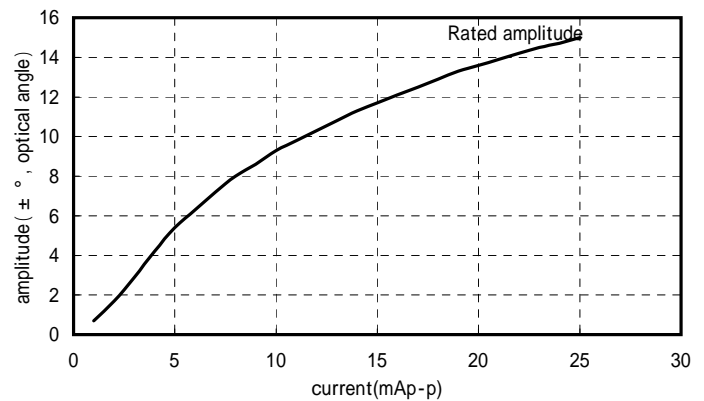

Characteristics of Current-amplitude
(Outside / DC driving)

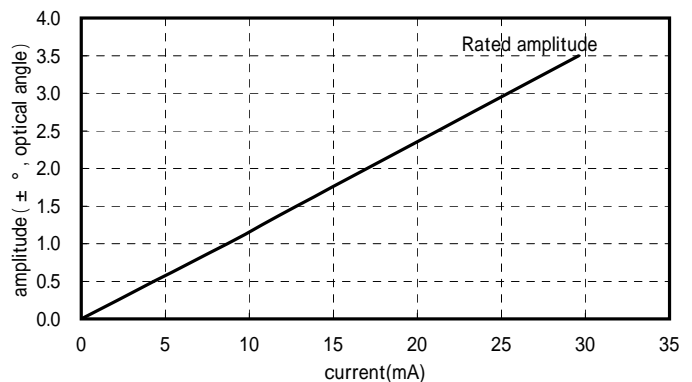

The above characteristics will may vary slightly depend on the individual variability of device, the ambient pressure & temperature, and long-term use.

LX9583A-203